

Camera Based Street Light Control System on FPGA Platform

Mrs. Anna Merine George¹, Mrs. Mary Ann George², Mrs. Susan G Varghese³

Manipal Institute of Technology, Manipal University, Manipal – 576104, anna_thanku@yahoo.com

Abstract: The paper includes a street light controller to provide high speed dimming depending upon the traffic density in each lane and luminance on the road surface. The luminance intensity on the road surface is measured using a digital camera that is calibrated using Macbeth Color Checker chart. The PWM required for the LED driver circuitry is generated using SPARTAN 3 FPGA.

Keywords: LDR, Street light control, FPGA, Camera Calibration

1. Introduction

LED street lighting is a solution for enhancing the quality of life and for improving the infrastructure in an efficient and cost effective manner. Fig.1 shows a road being lit by LED Luminaire.



Fig. 1 A road being lit by LED Luminaire

The first evidence of street lighting goes back to 10th Century when kerosene lanterns were installed along the main streets in Spain. From then on, street light has undergone several developments in technology. Coal gas lamps were used in the 19th Century and incandescent lamps emanated in the late 1800s. The last decade saw the advent of Light Emitting Diode (LED) being applied to street lights.

Automatic street light control is an easy and effective notion that uses MOSFET IRFZ540N as a switch to turn ON and OFF streetlights. It automatically turns light ON when the level of luminance on the road surface goes below 20 lux and turns OFF light when there is sufficient amount of sunlight on the road.

In rainy and Sunny days the ON and OFF time of the streetlights vary significantly. This is one the drawback of using timer based circuits or having manual controlled operation of streetlights. As compared a manual operated street light, there is significant reduction in the energy consumption of automatic controlled streetlights.

This is because the manually operated street lights are not switched off when there is sufficient daylight and not switched on before sunset.

A calibrated digital camera is used for luminance measurements on the road surface. As image based sensors are used for monitoring the traffic density on the road, the same camera can be used to measure the luminance intensity on the road surface and provide appropriate signals to street light.

Field Programmable Gate Arrays (FPGA's) are reconfigurable silicon chips that can be used to implement custom hardware functions. It provides hardware-timed speed, reliability, flexibility, low cost and hardware parallelism [9]. The recent trend of FPGA programming involves conversion of graphical block or c code into digital integrated circuits. Various MATLAB toolboxes like HDL coder and Fixed Point Design toolbox, Xilinx Vivado and HDL verifier can be used for the HIL simulation of the controller. Simulation assisted tools provide testing of the design before actual implementation [7]. The PWM based street light controller is tested on SPARTAN 3 FPGA.

2. Block Diagram

Automatic lighting control is a technology used to minimize the energy wastage by turning off artificial lights when not required. Energy efficient systems tend to use LED lights which provide scope for digital control, better energy saving and longer life span.

The street lights are Pulse Width Modulation (PWM) controlled in case of LED luminaire or controlled by using electronic ballast for Fluorescent Lamp (FTL). In this system the LED Luminaire of the street light is controlled using a driver which changes the light output with respect to the PWM signal generated [6]. A dimming system conserves energy compared to a non-dimming system, supposing that the lamps are dimmed and both schemes are working for comparable duration of time.

Solid state lighting technology makes use of semiconductor LED, organic LED or polymer LED rather than using electrical filaments, plasma or gas to create light.

An advantage of light emitting diode include the compact size of diodes, provide high lumen output, higher durability and shock resistance and provides unidirectional light emission.

The Fig.2 shows the block diagram for the street light control.

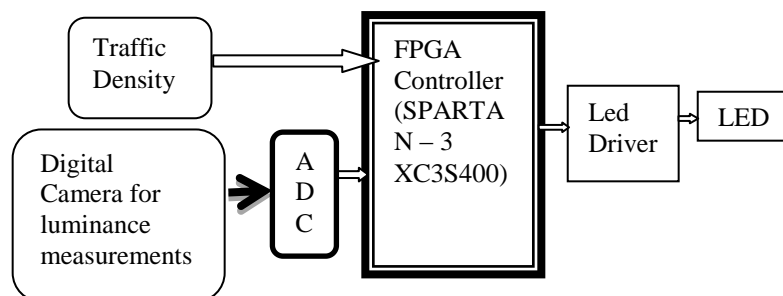

Fig.2: Block Diagram for Street Light Control

The entire design is divided into three parts – Digital Camera for luminance measurements, controller design for PWM generation and the output LED driver circuit.

2.1 HDRI Images and Camera Calibration for Luminance Measurements

High dynamic range (HDR) imaging is a technique used in imaging and photography to reproduce a greater dynamic range of luminosity than that is possible by using standard digital imaging or photographic techniques [3]. The process of creating HDR photographs is achieved by capturing multiple standard photographs using exposure bracketing and then merging them into an HDR image. PHOTOSPHERE is used to find luminance at

each point of an HDR image. HDRI technology can be used to calibrate a digital camera with the help of a luminance meter [3], [4].

In colour checker chart method of camera calibration, the actual luminance of each colour in the colour chart is measured using a luminance meter at specific lighting condition [3]. At the same lighting condition the Low Dynamic Range images of the chart is taken and the software luminance is found out from the image using MATLAB software.

HDRI images developed using MATLAB are used to estimate the luminance intensity on the road surface

The luminance value obtained using MATLAB is given to a flash type ADC using comparator IC LM339 (as shown in Fig.3) to make it compatible with the FPGA board.

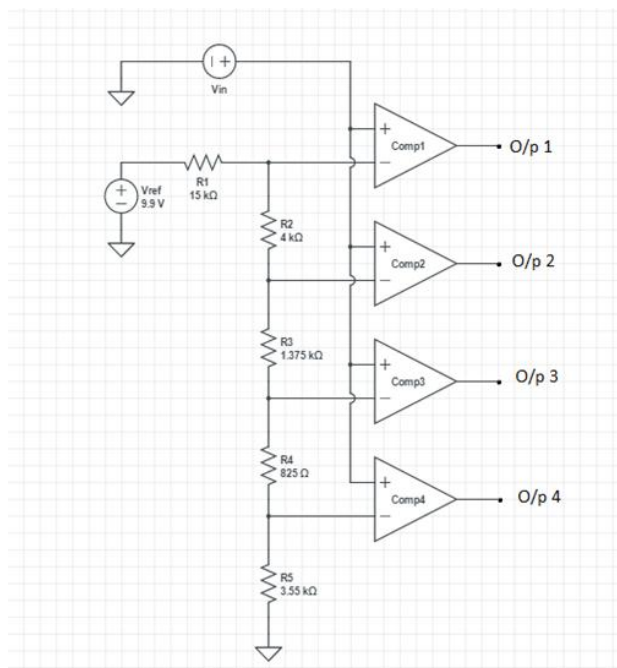

Fig.3: Flash Type ADC using Comparator IC LM339

2.2 Controller Design

Based on the traffic density and the amount of light on the road, different sensor outputs are generated. These are given as input to the controller. Only three levels of dimming (0%, 50% or 100%) are considered in this control scheme.

The threshold value of illuminance of the road surface is taken as 20 lux. Three different dimming levels as shown in Table 1 are obtained based on the illuminance on the road surface and accordingly the brightness level of the LEDs can be altered automatically.

Table 1: Dimming level based on Illuminance

Illuminance Range E (Lux)	Dimming (%)
$E > 20$	100
$10 < E < 20$	50
$E < 10$	0

Similar controllers have been used in daylight artificial light integrated schemes. [8]

2.3 PWM Generation

In this paper, VHDL programming is used to generate PWM pulses on Spartan 3 FPGA from Xilinx family. The PWM signals are given to the led driver circuit which in turn controls the switching of the LED light. The generated PWM pulses have a frequency of around 20 KHz which is required for the optocoupler. The duty cycle changes automatically depending upon the threshold and measured illuminance levels. The on-board clock frequency of 4 MHz is divided into 20 KHz frequency and the PWM signals are generated based on counter concept. Depending upon the digital output of the comparator that is given to the I/O pins of FPGA controller, different duty cycles are generated. This generated PWM signal with varying duty cycle is fed to the LED driver circuit.

2.4 LED Driver

The PWM output signal from the FPGA is fed to the LED driving circuit. The driver can automatically control the lamp brightness depending upon the change in the input PWM signal. In this paper, the generated PWM pulses have a voltage of 3.6V (TTL high). Optocoupler TLP250 is used to transfer electrical signals between two isolated circuits – FPGA and LED and a MOSFET IRFZ540N is used for fast switching of LEDs. The Fig.4 shows the LED driving circuitry used in the control scheme

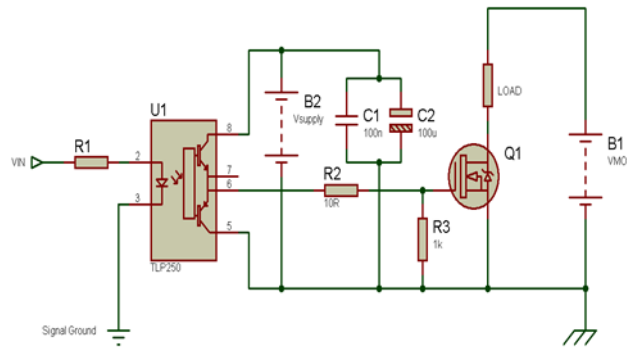

Fig.4: LED Driver circuitry

3. Results

The simulation for PWM generation for street light control is carried using Xilinx ISE Design Suite. Fig.5, Fig.6 and Fig.7 shows the PWM signals with 50%, 100% & 0% duty cycle.

Assuming that traffic density greater than or equal to 1,

Case1: When the illuminance E on the road is $10 < E < 20$.

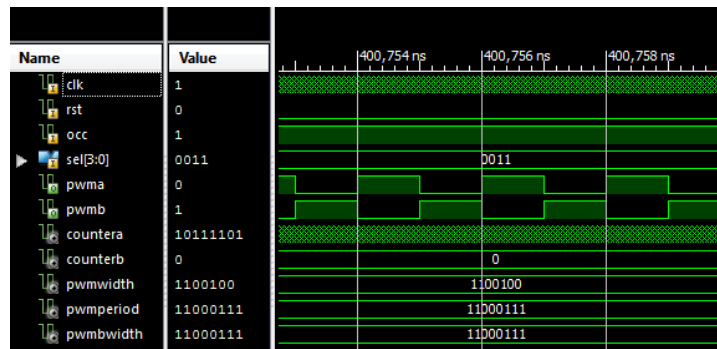

Fig.5: Simulation result for 50% duty cycle

Case 2: Illuminance E in the road is $E < 10$

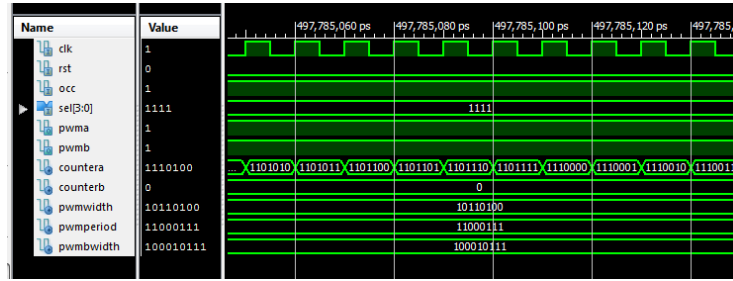

Fig.6: Simulation result for 100% duty cycle

Case 3: Illuminance E on the road is $E > 20$

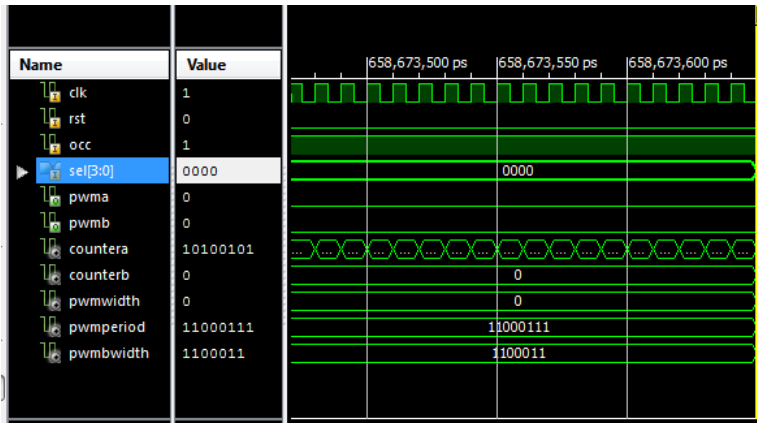

Fig.7: Simulation result for 0% Duty Cycle

After successful simulation of the code, it is synthesized on the FPGA kit and the output was verified by obtaining the PWM waveforms of the desired duty cycle on the Cathode Ray Oscilloscope. The following Fig.8, Fig.9 and Fig.10 demonstrate the results indicated on the CRO and Fig.11 shows the hardware test results.

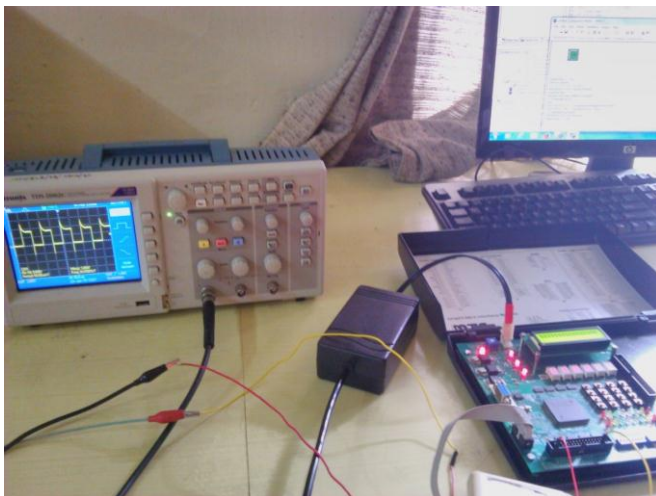

Fig.8: PWM Output on CRO for 50% Duty cycle

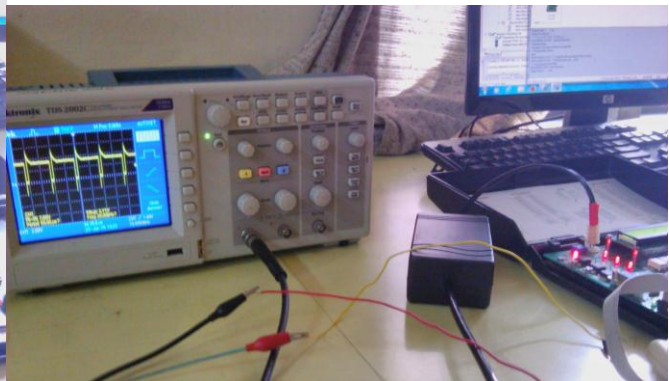

Fig.9: PWM Output on CRO for 100% duty cycle

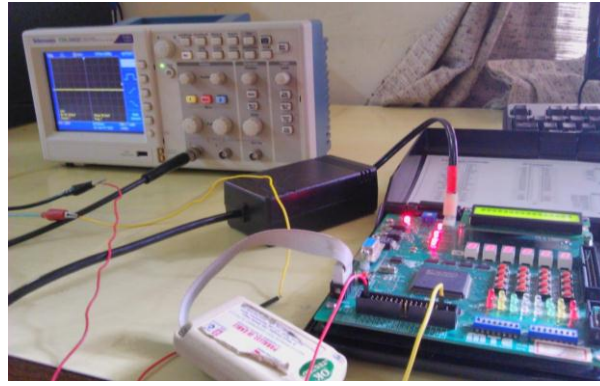

Fig.10: PWM Output on CRO for 0% duty cycle

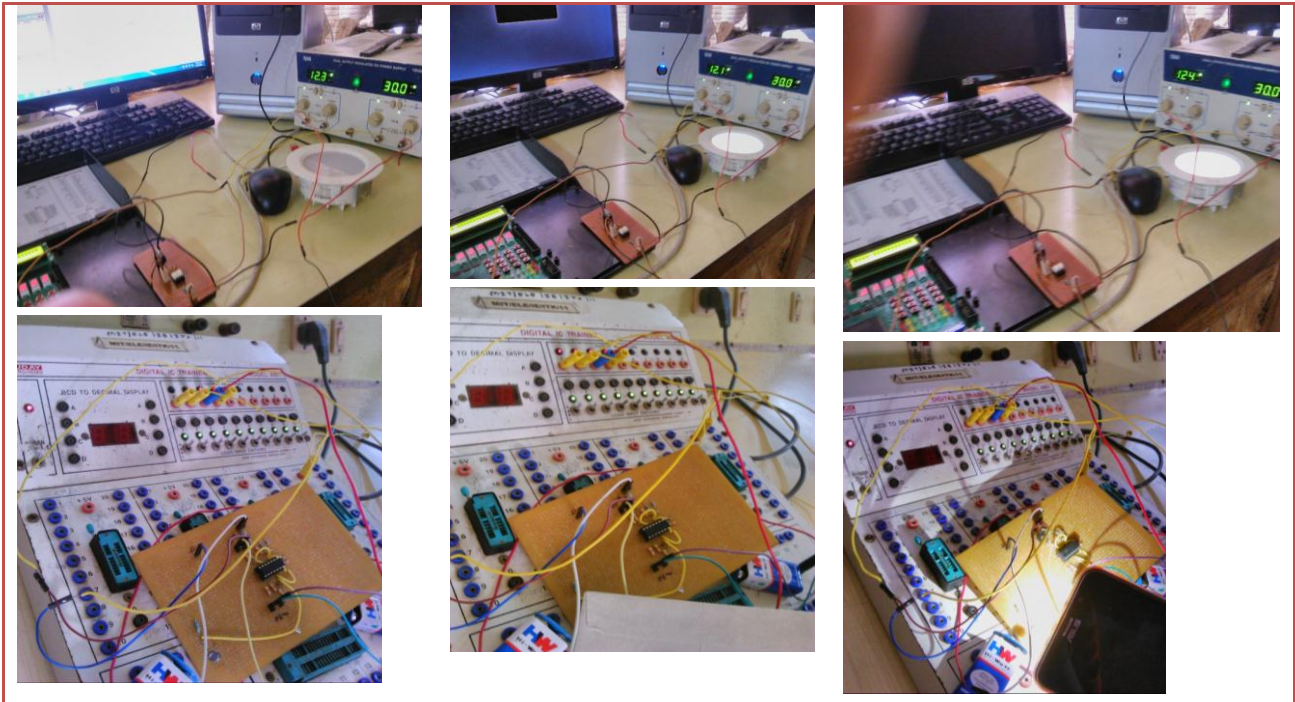

Fig.11: Hardware test results on the LED Lamp for different duty cycle.

4. Conclusion and Future Scope

A PWM based street light control is implemented on SPARTAN 3 FPGA. Different intensity level is obtained by changing the dimming level automatically based on the traffic density and the Camera sensor output.

Smart Street Lighting that can provide real time data on energy use, to provide remote control of strobing, flashing, integration with emergency services, and special event effects, in addition to basic controls for dimming and color adjusting has been the need for hour.

The HDRI system helps automation and is a promising approach for building energy management systems.

To address the challenges and efficient use of street lighting, solar powered LED street lights with Buck regulators can be used. The system will provide high speed dimming.

5. References

- [1] Rajendran Sinnadurai, M.K.A Ahamed Khan, Mohaamed Azri, Vikneswaran, “ Development of White LED Down Light for Indoor Lighting”, IEEE Conference on Sustainable Utilization and Development in Engineering and Technology, Oct 2012, pp.242-247.
- [2] High frequency dimming electronic ballasts designed to operate linear and Compact Fluorescent lamps, Specifier Reports Dimming Electronic Ballasts, Vol.7, No.3, October 1999.
- [3] Sudheer Kumar, Nithya Merin Jacob, Dr. Ciji Pearl Kurian, Dr. Kumara Shama. (2014). Calibration curves for luminance data acquisition using Matlab, International Journal of Engineering Research and Technology, 3(3) ISSN: 2278-0181.
- [4] Sudheer Kumar, Dr. Ciji Pearl Kurian, Susan G. Varghese, High Dynamic Range Imaging System for Energy Optimization in Daylight Artificial Light Integrated Scheme, International Journal of Renewable Energy Research, Vol.5, No.2, 2015.
- [5] Sudheer Kumar, Dr. Ciji Pearl Kurian, Dr. Kumara Shama, High Dynamic Range Image based Graphical user Interface for Glare and Uniformity analysis, International Journal of Applied Engineering Research, Vol.10, No.12, ISSN 0973-4562, 2015.
- [6] www.ti.com
- [7] Kurian, C. P. (2006). Advanced lighting simulation tools: An asset to assess energy saving potentials in lighting. *Lighting India magazine*, 78-89.
- [8] Colaco, S. G., Kurian, C. P., George, V. I., & Colaco, A. M. (2012). Integrated design and real-time implementation of an adaptive, predictive light controller. *Lighting Research and Technology*, 1477153512445713. <http://dx.doi.org/10.1177/1477153512445713>
- [9] Dilip, B., Alekhya, Y., & Bharathi, P. D. (2012). FPGA Implementation of an Advanced Traffic Light Controller using Verilog HDL, *International Journal of Advanced Research in Computer Engineering & Technology (IJARCET)*, 1(7), pp-1.